

# Garage Door Trim System





## **Keeps the elements on their side of the door.**

The Royal Garage Door System—including never rot brick mould, jamb and garage door stop—protects what's in the homeowner's garage from the weather and just about every other uninvited element. It's engineered to seal out dirt, bugs, wind, snow and water and match up beautifully with most garage styles and colors. Plus, its low-maintenance characteristics mean one-time installation.

## Uniflex™ Garage Door Stops

When it comes to garage door stops, little things are huge.

A repositioned flex mount for more versatile applications here. More uniform packing and less flex distortion there. It all adds up to patent-pending engineering that leads to happier homeowners everywhere.

### Uniflex advantages:

- 78% better flex adhesion
- Select colors engineered with new solar reflective technology
- Available in three widths:
  - 2" Standard
  - 2 5/8" R&R
  - 3 1/4" Architectural

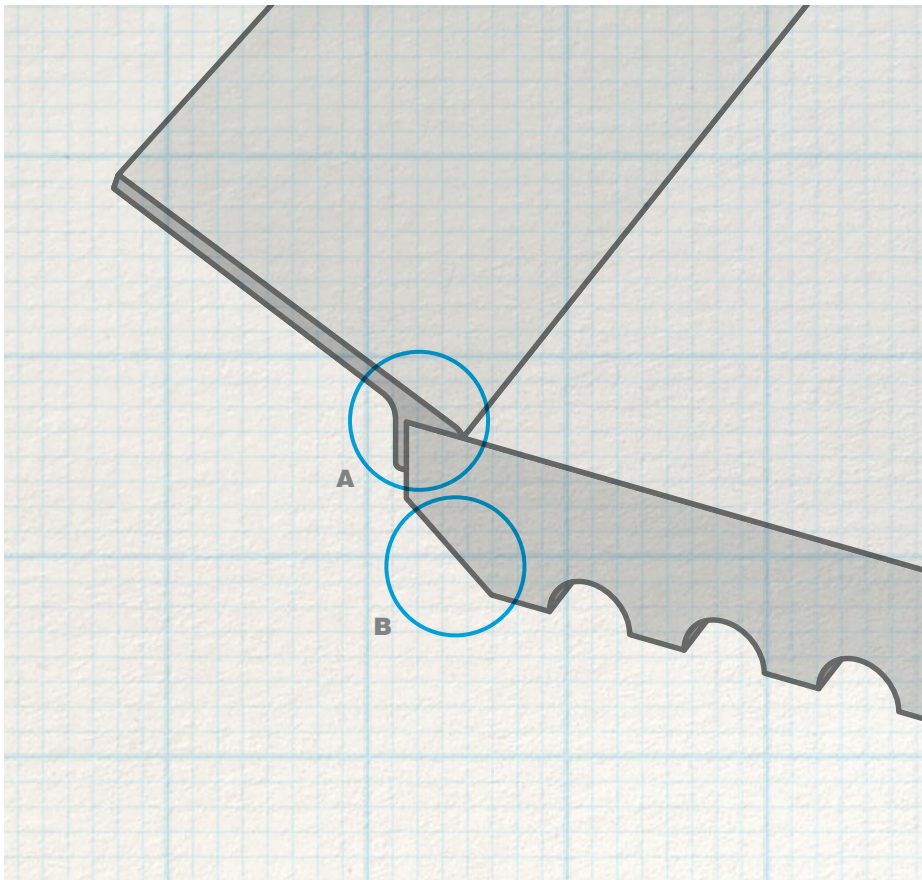

**A** Brand new design repositions flex mount to accommodate top and side mount applications.

**B** Patent-pending profile design creates uniform packing and significantly reduces flex distortion.

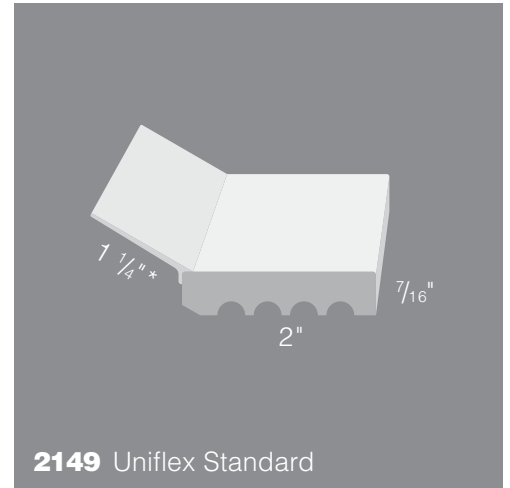

**2149** Uniflex Standard

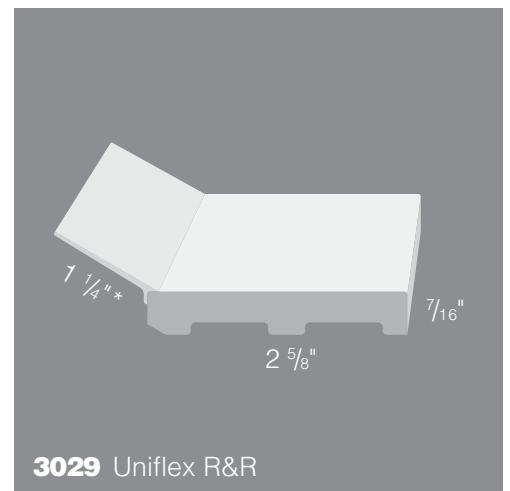

**3029** Uniflex R&R

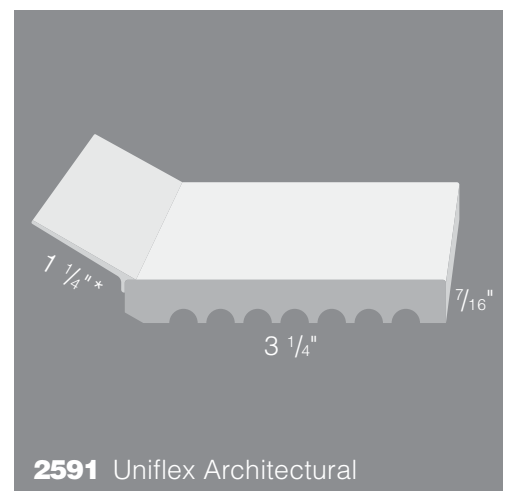

**2591** Uniflex Architectural

**Features and benefits:**

- Limited 25 year warranty
- Moisture resistant
- Seals out dirt, bugs, wind, snow and water
- Dent resistant
- Strong and durable
- Reduces energy costs
- Termite proof

# Colorful stopping power and heat resistance.

Colors are important design elements, so we offer 30 of them, which we frequently update to match the latest color trends<sup>1</sup>. Because darker colors absorb more light and heat, we've also enhanced those colors with our Royal Solar Reflective™ formulation.



**Standard Colors<sup>2</sup>**



**Solar Reflective Colors<sup>2</sup>**

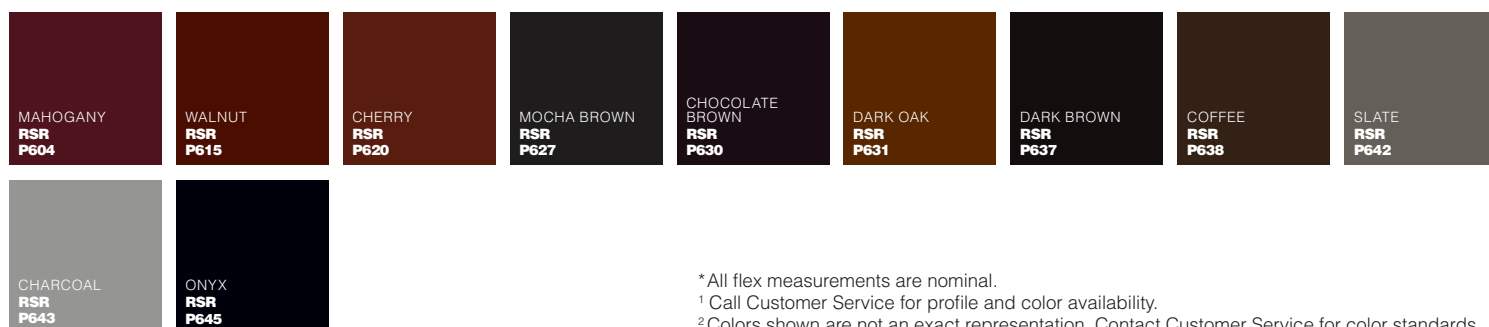

\* All flex measurements are nominal.

<sup>1</sup> Call Customer Service for profile and color availability.

<sup>2</sup> Colors shown are not an exact representation. Contact Customer Service for color standards.

## Garage Door Jamb and Brick Mould

Our garage door stops are just the start.

Our garage door jambs and brick moulds are made from the same weather-resistant PVC as our garage door stops. They come through with the same element-sealing insulation and low-maintenance performance. Our "no rot" entry system jamb profiles are available in both woodgrain and smooth finishes.

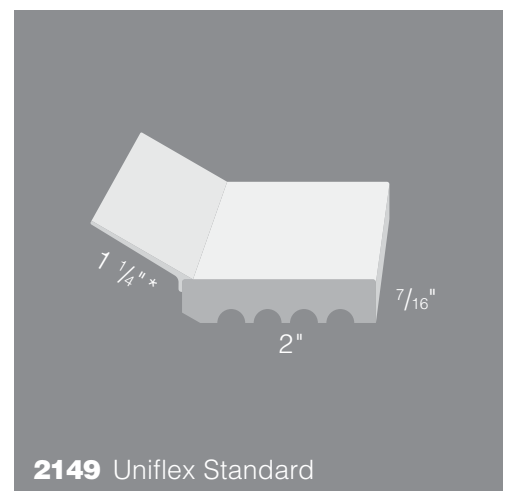
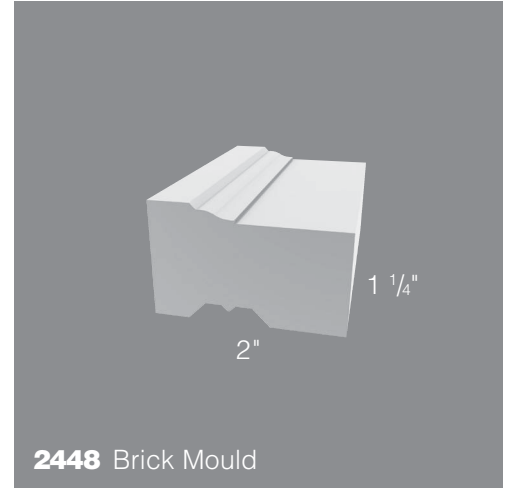

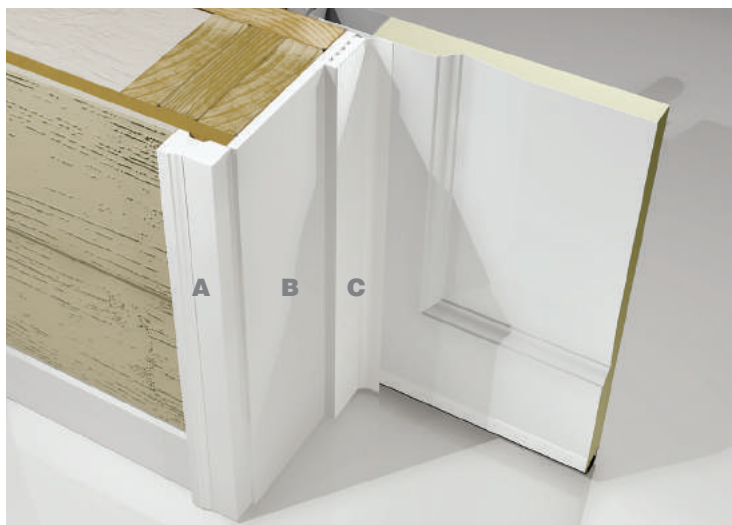

**A** Brick Mould   **B** Jamb (non load-bearing)   **C** Garage Door Stop

### What makes our garage door trim system great:

- Faster to install than aluminum
- Damage and dent resistant
- Mold and mildew resistant
- No painting needed
- Performs year after year
- Insulates 70% better than wood
- All three trim system components are a perfect color match



WOODGRAIN

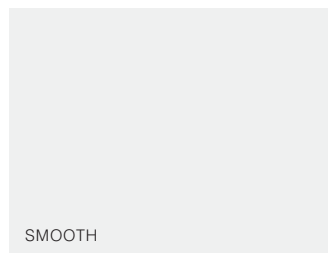

SMOOTH

All door jambs come with a reversible texture that's woodgrain embossed on one side and smooth on the other.



# Installation Tips

## SAWING/CUTTING

- Use shears or utility knife.
- Use standard woodworking equipment for most applications.
- If using a power miter saw, a carbide-toothed blade with 80 teeth or more is recommended.

## NAILING

- Use 6D and 8D galvanized nails.
- Pre-drilling is required at temperatures of 40°F or below.
- Trim can also be installed using a pneumatic nailer, with stainless steel or painted head screws or with construction-grade adhesives.

## GLUING

- Temperature variations will cause PVC mouldings to expand and contract. To prevent open miter joints, we highly recommend gluing all joints on PVC mouldings using a quality instant glue, PVC cement.
- When assembling, splice and return miters by gluing the mouldings together before installation. This will allow you to fit the joints easily and fasten the trim to the wall as one unit.
- Always test adhesive brands before using.

## PAINTING

- Royal Mouldings require no painting for protection, but can be painted with 100% acrylic latex paint to achieve custom colors. Scuff sanding will optimize paint adhesion, but is not required. A second coat may be needed to achieve desired color.
- To maintain warranty for custom colors in darker shades, use heat-reflective paint with VinylSafe™ Technology from Sherwin-Williams. Dark colors are considered any color that falls within the lightness (L) value of 56 to 0, with 100 being white and 0 being black.

## TOUCH-UP FOR EXTERIOR MOULDINGS

- Dap® "All Purpose" Painter's Putty®
- Minwax High Performance Wood Filler®
- Sherwin-Williams Shrink Free Spackling®

After installation is complete, caulk and/or putty all gaps and nail holes.

## CLEANING

- Royal Moulding can be cleaned using any of the recommended household cleaners, however, glass cleaner has been shown to be best at keeping the finish intact.
- Recommended cleaners: See list in FAQs.
- Apply the cleaning solution and immediately wipe dry for best results.
- Avoid harsh cleaners with glycol ethers, ethanol type solvents and/or isopropyl alcohol, as they can soften the PVC finish if left on for several minutes.



# Garage Door Stop Handling Instructions

## BRICK MOULD & JAMB INSTALLATION

1. Remove old jamb, brick mould and garage door stop with a pry bar or hammer.
2. Measure the top opening from side to side and cut jamb to fit with a fine tooth power or hand saw.
3. Install top jamb piece using 8D galvanized finishing nails to 2x4 or 2x6 structural frame members. Alternate nailing from side to side, nailing every 12" and approximately 3/4" from each edge. Note: If nailing product at 40°F or below, pre-drilling is required.
4. Measure and cut jamb side pieces to fit from top jamb to floor. Nail as directed.
5. Measure top brick mould to overlap the jamb material by 1/2". This will allow for a 1/8"–1/4" reveal around the jamb. Reveal should be both on top and sides. Cut 45° angle on ends, butt or angle joint middle seam if needed.  
Note: Reveal may vary depending on siding, siding J-channel, brick or block installation.
6. Install brick mould using 10D or 3" galvanized finishing nails, spaced 12" on center. Use PVC cement in the mitered joint for optimum fit. Note: Nails should penetrate structural frame at least 1".
7. Measure and cut side brick mould trim to fit. Install as directed.

## GARAGE DOOR STOP INSTALLATION

1. When installing garage door stop alone, open the garage door and remove old door stop with standard claw hammer.
2. Close garage door. Begin garage door stop installation by measuring and marking 1/2" from outside of garage door several places around the jamb. Connect the marks with a straight edge, then open door again.
3. Measure top opening from side to side and cut garage door stop ends square with fine tooth power or hand saw.
4. Place grooved side against jamb and inner edge, (where hard vinyl joins weatherstrip) along marked lines. Nail in place with 6D galvanized finishing nails in the pre-punched nail guides or 8" on center.
5. Measure and cut each piece to fit, from top piece to floor. With grooved side against jamb, position nail as directed.
6. For a good drainage and overlap, trim side stop pieces at a 45° angle with scissors where the soft vinyl weatherstripping meets the top.



### SAFETY FIRST



### STORE FLAP UP IN BOX



### OPTIMAL STORAGE TEMPERATURE CONDITIONS

35°F to 90°F (1°C to 32°C)



### TRANSPORT BRACED AND FLAT



### TRIM/CUT

Shear, Saw, Knife

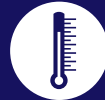

### INSTALL GAPS

Above 70°F: tight, 70°F-40°F: 1/16", Below 40°F: 1/8"  
(Above 21°C: tight, 21°C-4°C: 1/16", Below 4°C: 1/8")



### PRE-DRILL

Below 40°F (Below 4°C)



### FASTENERS

6D Galvanized, 15-16 Gauge, #7-#8 SS Screw



### NAIL GUN PRESSURE

60 to 80 PSI



### SCREW/NAIL

Every 8"

# FAQs

---

## **What is the best caulking to use with your brick mould, thermo stop and jamb?**

We recommend using Liquid Nails Super Caulk Window & Door LC130 for indoor/outdoor use.

## **How do you clean the product?**

We recommend cleaning our exterior mouldings with the following cleaners: Windex®, Glass Plus®, 409® Glass & Surface Cleaner, Spic and Span®, Cinch®, Fantastik® All-Purpose, Regency® Glass & Surface, Clorox® Clean-Up® or Fantastik® Orange Action®. The cleaning solution should be applied and immediately wiped dry. The cleaning solution should not be left to stand on the components for an extended period of time.

## **What surfaces can your moulding be attached to: plaster, stucco, vinyl, brick, concrete, wood?**

The moulding can be attached to any of the above surfaces.

## **How do you cut the moulding?**

Royal Mouldings can be cut using standard woodworking equipment. If using a power miter saw, we recommend using a carbide-toothed blade with 80 teeth or more.

## **Do you have to pre-drill before nailing?**

If nailing product at 40°F or below, pre-drilling is required.

## **What kind of nails do you use?**

Royal Mouldings can be installed with nails or construction adhesive. If nailing, use galvanized finishing nails for exterior applications. Place nails 12" on center approximately 3/4" from each edge.

## **Can you use a nail gun on your products?**

Royal Mouldings can be installed using pneumatic nail guns.

## **Can I use screws in your moulding?**

Yes, we recommend a non-corrosive metal such as galvanized, stainless or coated screw for exterior applications.

## **What is Solar Reflective?**

Royal Solar Reflective (RSR) material is a product performance advancement that provides much greater in-the-field performance against warping, bowing and other Thermal issue in (warm or hot arid) climates.



Royal® Building Products exists for one reason: to push the limits of what every type of exterior can be. We strive for best-in-class manufacturing and industry-leading innovation. What drives us? Every homeowner who demands exteriors that add value, perform impeccably, look amazing and make their lives easier. Our goal is to bring more products, more styles, more technology, more design insight and more sustainable solutions to the attention of everyone who cares about creating the best exterior possible. Build Royal™

# Build™



CELECT® CELLULAR COMPOSITE SIDING



ZURI® PREMIUM DECKING



ROYAL® TRIM & MOULDINGS



HAVEN® INSULATED SIDING



ROYAL® VINYL SIDING



ROYAL® SHUTTERS, MOUNTS & VENTS



ATLAS STONE™



PORTSMOUTH™ SHAKE & SHINGLES



CEDAR RENDITIONS™ ALUMINUM SIDING

 **ROYAL® Building Products**  
A Westlake Company

For product warranty details, please visit [RBPWarranty.com](http://RBPWarranty.com)

© 2020 Royal Building Products